

## The Multiple Protection



### FEATURES

- Three-door design for maximum function varieties
- Side compartment for fiber, MDF/VDF modules or embedded climate control equipment
- Fans can be added on the top cover for extra ventilation

### OVERVIEW

No matter what your application, OPTiLite has there sources and experience to understand the requirement and to design and build a product to meet the most stringent standards. Over 20 years of experience in delivering customized one-stop solutions: Product Modification, Completely New Product, Indoor & Outdoor, Climate Controlled, Cabinets & Enclosures & Shelters, and Accessories

### CONSTRUCTION

Available in these heights (in mm):

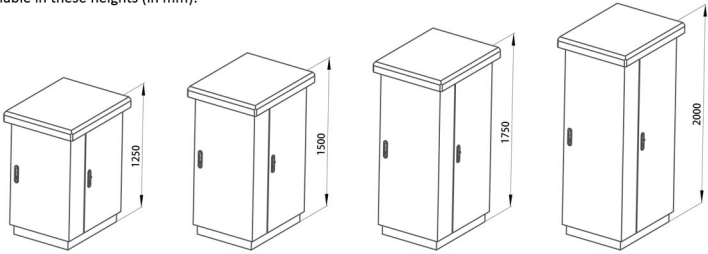

Available in these depths (in mm):

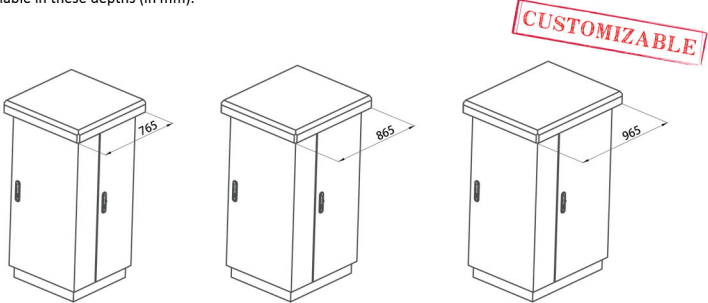

### OTHER OPTIONS

	Power. 110-240V		Laptop Tray		Door Alarm		Optical Splitter
	Power Supply (Breaker, Rectifier, Monitor)		L Rail Set		Water Alarm		Splice Tray
	Ground bar kit. 10-position		Interior Light		Smoke Alarm		Distribution Module
	19" or 23" Mounting Panel		Heater		Dynamic Environment Monitoring Systems		19" or 23" Relay Racks
	PDU		Fan		Generator Plug & Interlock		Mounting Base
	Battery: AGM VRLA Batteries		Air Conditioner		Door Latch Tool		
	Battery Storage		Heat Exchanger		Solar shield roof		